

Examenopdrachten KPC SVA 1

Opdracht 1.

Handmatig Knippen

Opdracht 2.

Handmatig Zagen

Opdracht 3.

Afbramen en Vijlen

Opdracht 4.

Boren

Opdracht 5.

Tappen

Opdracht 6.

Zetten

Opdracht 7.

Puntlassen



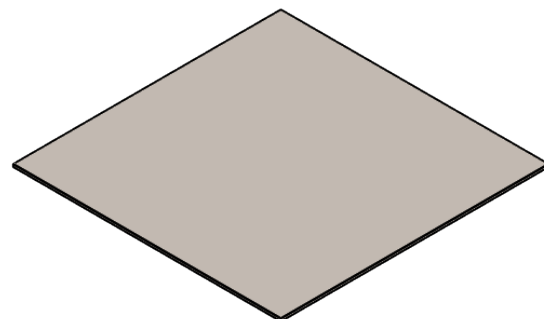
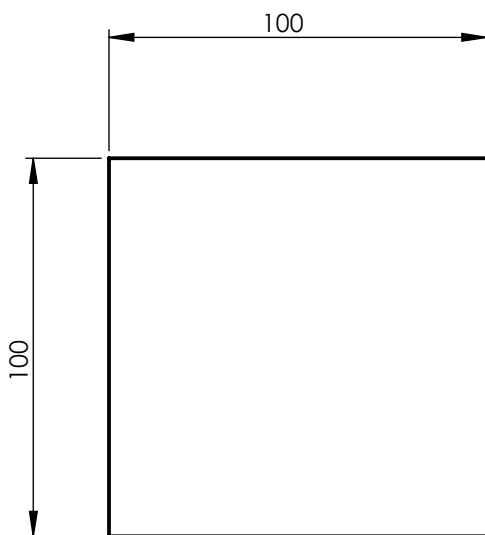
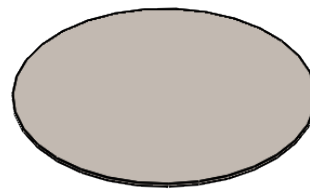
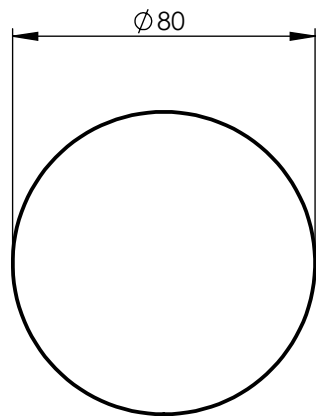

In overleg met de examinerator mag afgeweken worden van maatvoering en/of materiaalsoort

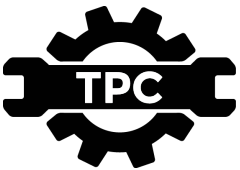
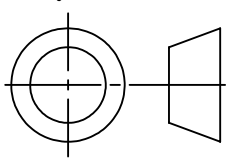
2	Handmatig knippen rond	Ø80		1	Plaat 1 mm
1	Handmatig knippen vierkant	100	100	5	Plaat 1 mm
Nummer	Naam	Lengte in mm	Breedte in mm	Aantal	Materiaal
 Tel: 0314 393921 www.tpcdoetinchem.nl	Projectie:  Amerikaanse projectie Maten zijn in mm	Werkstuk naam:		Product naam:	
		SVA 1:Handmatig knippen		Handmatig knippen	
		Getekend op: 31-10-2019		Schaal: 1:2	
		Gewijzigd op: 8-10-2021			

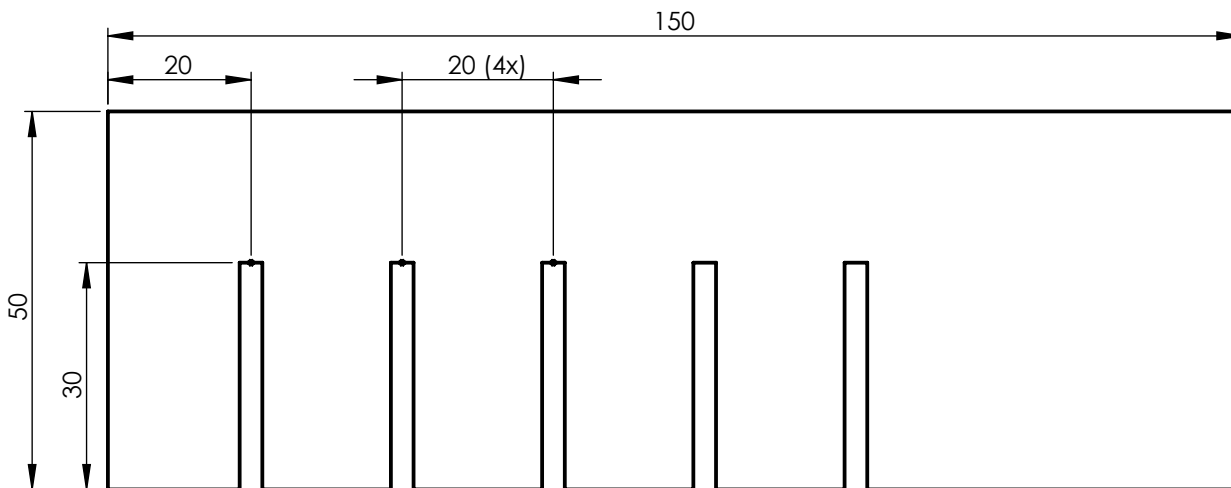
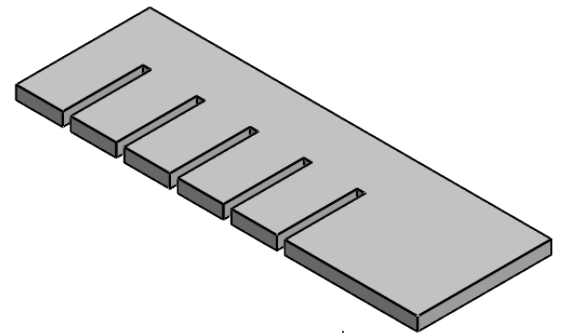
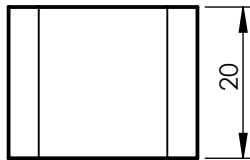
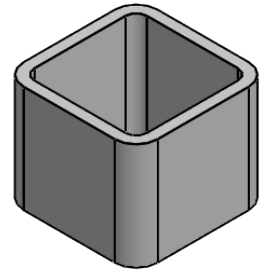
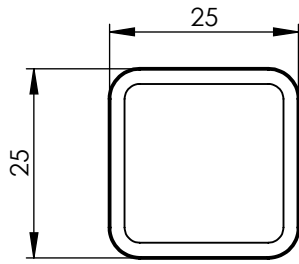

In overleg met de examiner mag afgeweken worden van maatvoering en/of materiaalsoort.

2	Handmatig zagen deel 2	25	25	1	Koker 2 mm
1	Handmatig zagen deel 1	150	50	1	Strip 6 mm
Nummer	Naam	Lengte in mm	Breedte in mm	Aantal	Materiaal

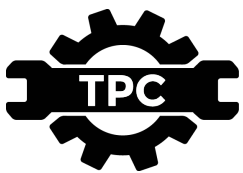

Tel: 0314 393921
www.tpcdoetinchem.nl

Projectie:

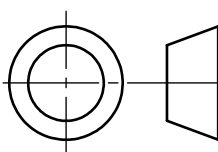

Americaanse projectie
Maten zijn in mm

Werkstuk naam:

SVA1: Handmatig zagen

Getekend op:

31-10-2019

Gewijzigd op:

8-10-2021

Product naam:

Handmatig zagen

Schaal:

1:1

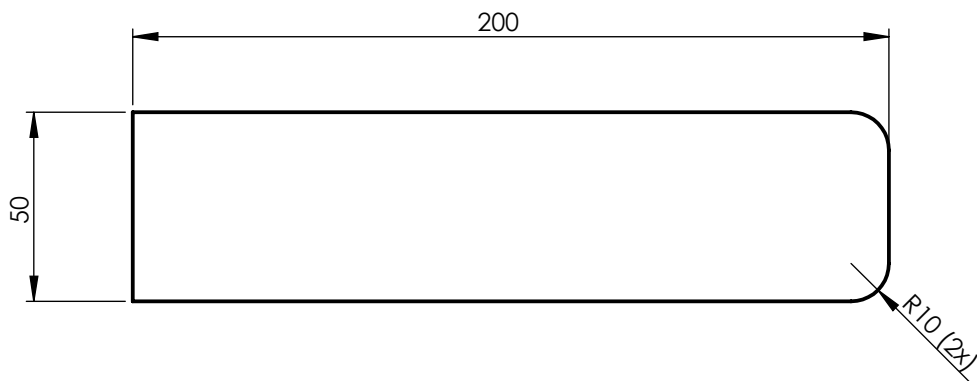
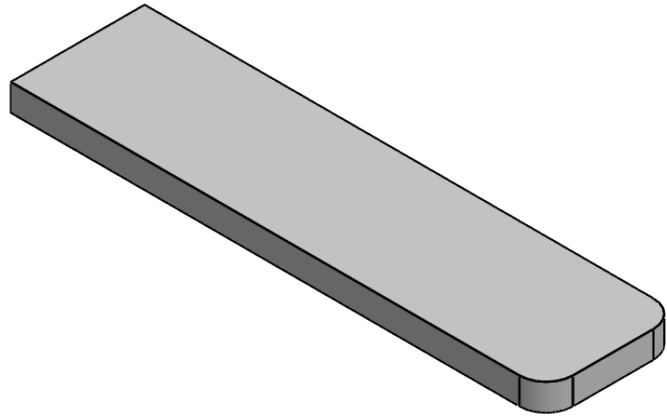

In overleg met de examinerator mag afgeweken worden van maatvoering en/of materiaalsoort.

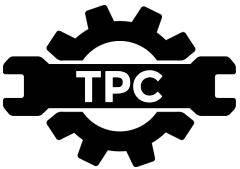
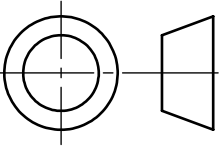
1	Handmatig vijlen	200	50	1	Plaat 6 mm
Nummer	Naam	Lengte in mm	Breedte in mm	Aantal	Materiaal
 Tel: 0314 393921 www.tpcdoetinchem.nl	Projectie:  Amerikaanse projectie Maten zijn in mm	Werkstuk naam:		Product naam:	
		SVA1: Afbramen en vijlen		Handmatig vijlen	
		Getekend op: 1-11-2019		Schaal: 1:2	
Gewijzigd op: 8-10-2021					

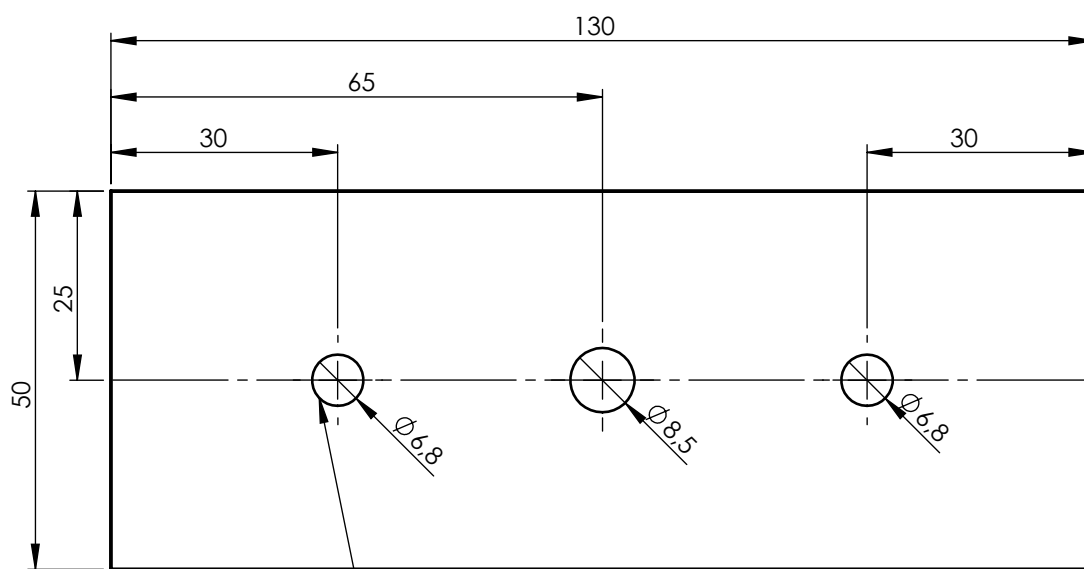
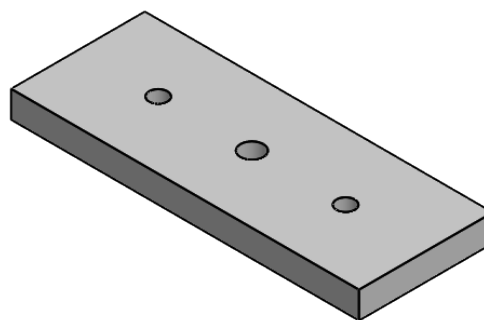

Alle gaten kantje breken (verzinken)

In overleg met de examinerator mag afgeweken worden van maatvoering en/of materiaalsoort.

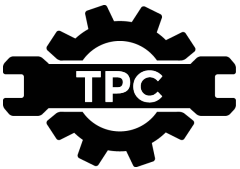
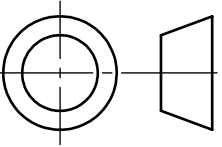
Nummer	Naam	Lengte in mm	Breedte in mm	Aantal	Materiaal
1	Boren	130	50	1	Plaat 6 mm
 Tel: 0314 393921 www.tpcdoetinchem.nl	Projectie:  Amerikaanse projectie Maten zijn in mm	Werkstuk naam:		Product naam:	
		SVA1: Boren met de kolomboormachine		Boren	
		Getekend op: 1-11-2019		Schaal: 1:1	
		Gewijzigd op: 8-10-2021			

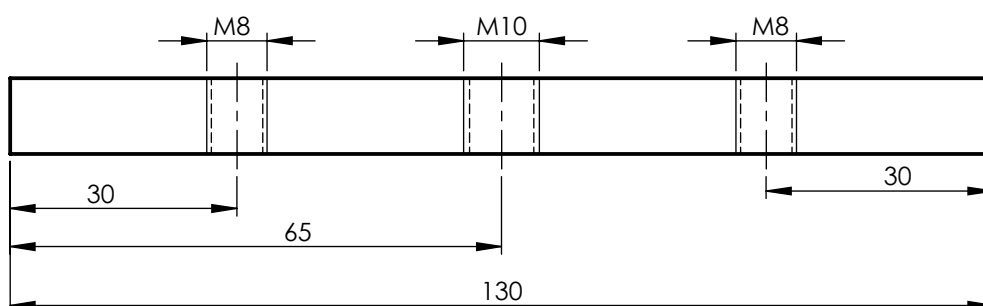
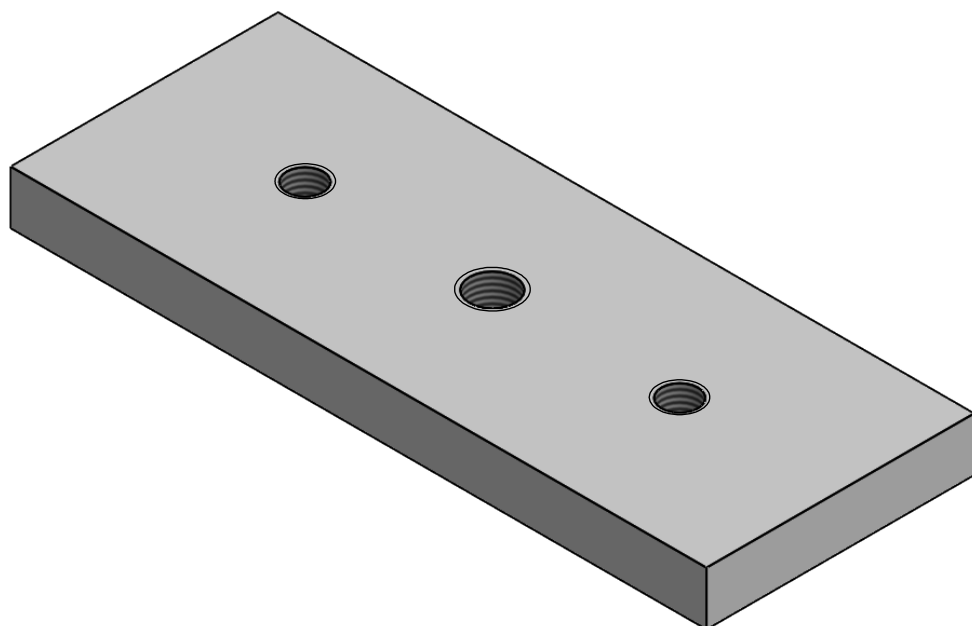

In overleg met de examinerator mag afgeweken worden van maatvoering en/of materiaalsoort.

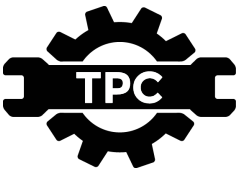
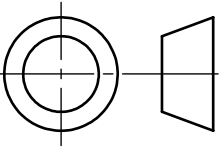
1	Tappen	130	50	1	Plaat 6 mm
Nummer	Naam	Lengte in mm	Breedte in mm	Aantal	Materiaal
 Tel: 0314 393921 www.tpcdoetinchem.nl	Projectie:  Amerikaanse projectie Maten zijn in mm	Werkstuk naam:		Product naam:	
		SVA1: Tappen		Boren	
		Getekend op: 1-11-2019		Schaal: 1:1	
Gewijzigd op: 8-10-2021					

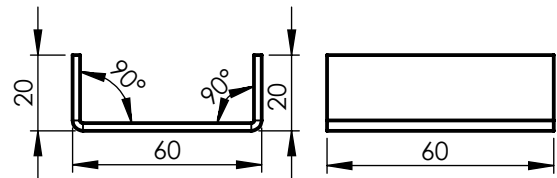
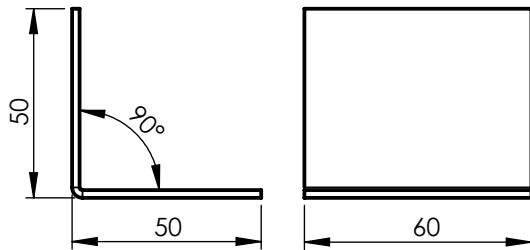
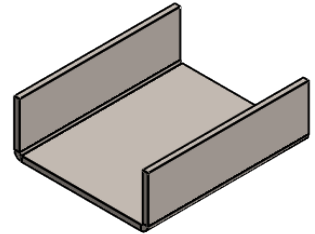
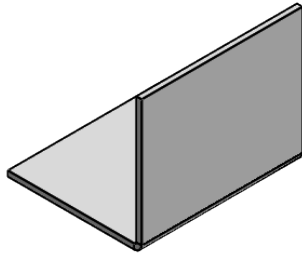

In overleg met de examinerator mag afgeweken worden van maatvoering en/of materiaalsoort.

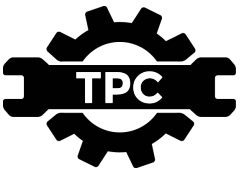
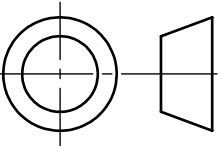
2	U vorm	100	60	1	Plaat 2 mm
1	Haakse hoek	100	60	1	Plaat 2 mm
Nummer	Naam	Lengte in mm	Breedte in mm	Aantal	Materiaal
 Tel: 0314 393921 www.tpcdoetinchem.nl	Projectie:  Amerikaanse projectie Maten zijn in mm	Werkstuk naam:		Product naam:	
		SVA1: Zetten		Zetten	
		Getekend op: 1-11-2019		Schaal: 1:2	
		Gewijzigd op: 8-10-2021			

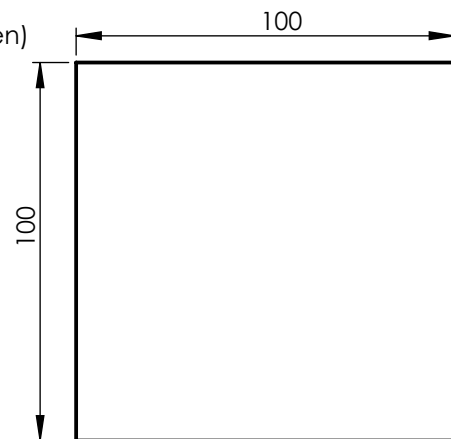
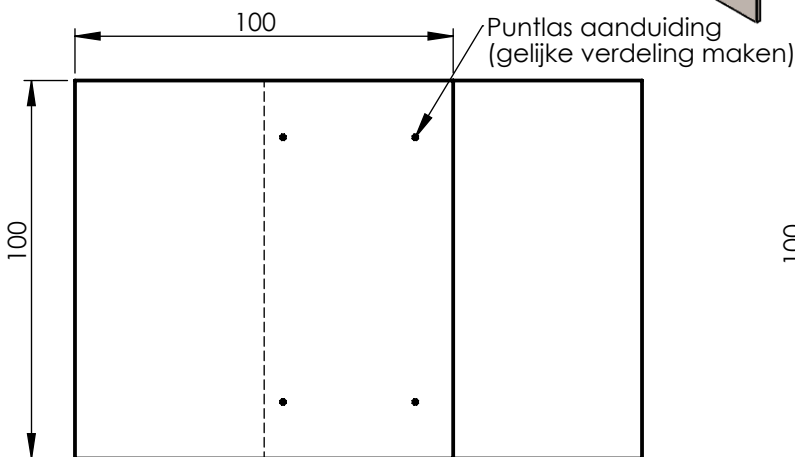
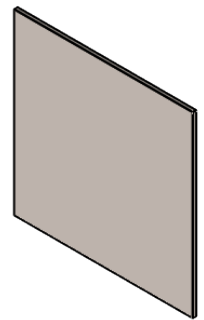
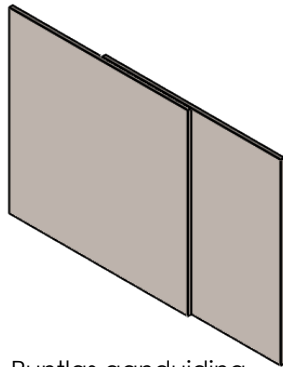
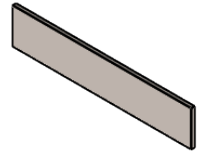
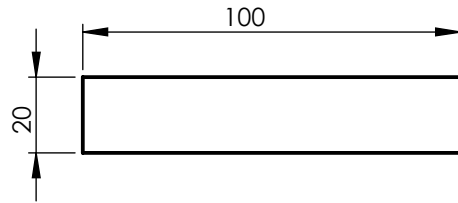
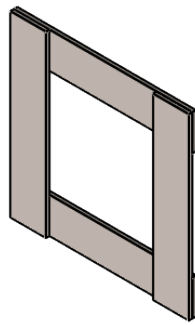
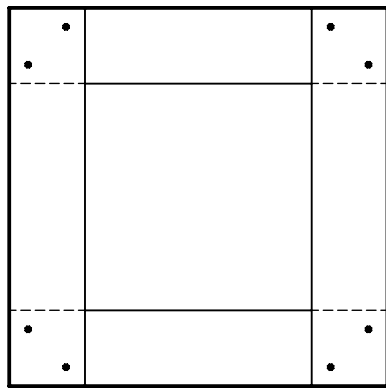

In overleg met de examinator mag afgeweken worden van Maatvoering en/of materiaalsoort.

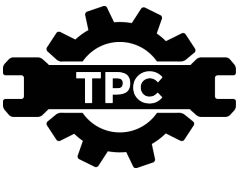
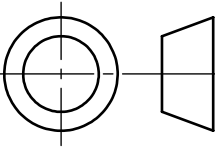
2	Puntlas deel 2	100	20	4	Plaat 2 mm
1	Puntlas deel 1	100	100	2	Plaat 2 mm
Nummer	Naam	Lengte in mm	Breedte in mm	Aantal	Materiaal
 Tel: 0314 393921 www.tpcdoetinchem.nl	Projectie:  Amerikaanse projectie Maten zijn in mm	Werkstuk naam:		Product naam:	
		SVA1: Puntlassen		Puntlassen deel 1 Puntlassen deel 2	
		Getekend op: 1-11-2019		Schaal: 1:2	
		Gewijzigd op: 8-10-2021			